

ATP- 80KC / ATP- 80KCP

High-quality Thermal Printer for ATMs and Ticket Terminals

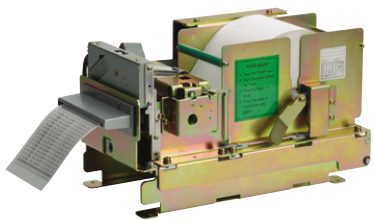

ATP- 80KC

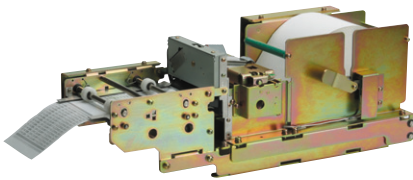

ATP- 80KCP

Feature

- ▶ Capable of loading large diameter roll paper(150 φ)
- ▶ Paper presenter(ATP-80KCP)

Application

- ▶ Ticket terminals
- ▶ Information / Internet kiosk
- ▶ Vending machines
- ▶ Automated Teller Machines(ATMs)
- ▶ Gambling and lottery machines
- ▶ Analyzers
- ▶ Receipt printer

Specification	ATP-80KC	ATP-80KCP
Printing System	Horizontal Direct Thermal	Horizontal Direct Thermal
Resolution	8dots/mm	8dots/mm
Print Width	80mm(640dots)	80mm(640dots)
Paper Feeding Method	Friction Feeding	Friction Feeding
Print Speed	100mm/sec(Max.)	100mm/sec(Max.)
Drive Voltage	Motor/Head 24V ± 5%, Logic 5V ± 5%, Sensor 5V ± 5%	Motor/Head 24V ± 5%, Logic 5V ± 5%, Sensor 5V ± 5%
Number of column	26columns(24x24), 40columns(16x24)	26columns(24x24), 40columns(16x24)
Interface	RS-232C / Parallel	RS-232C / Parallel
Head Up Detector	Mechanical switch	Mechanical switch
Head Life	50km	50km
Cutting System	Guillotine style	Guillotine style
Cutting Width	63mm	63mm
Cutter Life	300,000 cuts	300,000 cuts
Weight	Approx. 1,400g	Approx. 1,400g
Dimensions(mm)	132(W) x 263(L) x 152(H)	143(W) x 396(L) x 116(H)
Presenter	-	Included
Power Supply	Supply on customer request	

Design, Specifications are subject to change without notice. Ask factory for technical specifications before purchase and/or use. Whenever a doubt arises form this products, please inform us immediately for technical consultation without fail.

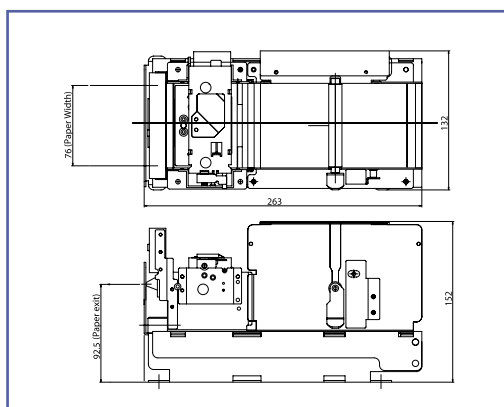

ATP- 80KC

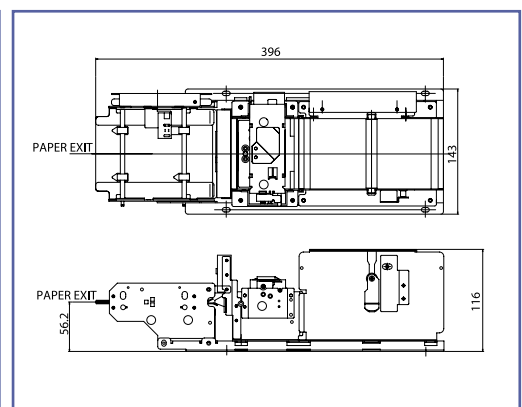

ATP- 80KCP